

INSTALLATION, OPERATION & MAINTENANCE INSTRUCTIONS

GENERAL INFORMATION

1. Purge the lines of all foreign material, (welding slag, pipe scale, dirt, thread chips etc.). The installation of an upstream strainer may be necessary in dirty systems.
2. Air should be purged from the system prior to startup to assure quiet operation and to avoid water hammer.
3. Hays PurePIC™ Pressure Independent Control Valve should be installed upwards with respect to horizontal plane as shown under installation section. The actuator should always be coupled with the valve body. Straight sections of pipe upstream or downstream of the Hays valve are not necessary for proper operation.
4. Hays PurePIC™ Pressure Independent Control Valve are marked with direction of flow and the range of design flow rates that can be controlled on that specified model.

THE FLOW ARROW MUST POINT IN THE DIRECTION OF FLOW FOR PROPER OPERATION.

5. The actuator has a linear stroke and the PurePIC™ should be ordered based on design flow rate which will be preset when shipped. During operation under modulation, the flow can be set below design flow with respect to stroke proportional to voltage signal and new set flow rate will be maintained constant across the published pressure differential range. See Figure 1 below for a representation of the general operation of PurePIC™ model.

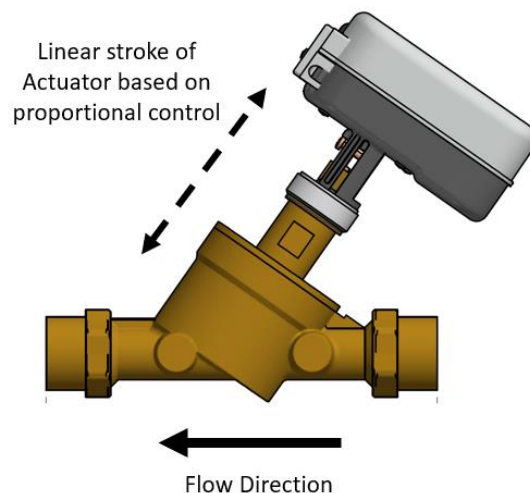

Figure 1: PurePIC® Pressure Independent Control Valve model

6. Hays PurePIC™ Pressure Independent Control Valve are factory assembled, and individually calibrated. When properly installed, the valves are warranted to be accurate within 10% of rated set flow rate in the field.
7. Contact Hays for part numbers, instructions, and other details.

OPERATION

1. For optimum operation, air entrainment in the system must be eliminated. The flow control valve must remain filled with fluid. The system must be clean and free of foreign materials.

2. Hays PurePIC™ Pressure Independent Control Valve must only be used with fluids that are compatible with, Brass, and EPDM materials. The temperature during operation must be limited to the range of 32 °F to 225 °F.
3. The use of fluids having a specific gravity different from that of water will require adjustment. Valves specified for fluids other than water will be marked and the factory calibration will take the specific fluid's properties into consideration.
4. Operation at a temperature other than the rated temperature may require a correction.

INSTALLATION

1. Threaded connections for this respective model are provided with ½” and ¾” Dryseal NPT threads in accordance with ANSI STD B1.20.1 and are intended for use in Building Services Piping meeting the requirements of ASME B 31.9. Apply thread sealant to male pipe threads, starting with the second or third thread from the end, and torque the connection to 75 foot pounds per inch of pipe size minimum.

Example: For ½”, use $0.5 \times 75 = 38$ ft lb. minimum.

2. Sweat connections for this respective model have their end connections formed to ANSI STD B16.22 requirements and are intended for use in Building Services Piping meeting the requirements of ASME B 31.9. The Temperature/Pressure rating of the Solder Joint is dependent upon the type of solder used. ANSI STD B16.22 Pressure Ratings should be reviewed prior to selecting a solder and sweating.

Union end pieces on the valves are shipped loose and should be removed for sweating. The O-ring must be removed and stored during the operation. The outside of the tubing, and the inside of the fitting are to be mechanically cleaned and then lightly coated with solder flux. The tube is then inserted one diameter into the fitting, and the **CENTRAL PORTION OF THE VALVE BODY WRAPPED WITH A WET RAG**. Heat may be applied, either to the tubing or to the end of the fitting to achieve solder flow. When the parts have achieved the necessary temperature, solder is to be added to the joint and the joint allowed to cool. The heat is to be applied for the shortest time possible.

The internal parts of Hays PurePIC® Pressure Independent Control Valve are capable of continuous use at normal soldering temperatures but will be quickly damaged at higher temperatures. When soldering vertical connections care must be taken not to permit excess solder to drip into the valve. Heat discoloration from the sweating operation should not extend to the major diameter of the valve body.

If disassembled, the valve must be reassembled in reverse order, with all the parts returned to their original positions. The union o-ring being the last item installed prior to tightening the union nut hand tight, followed by tightening ¼ turn with appropriately sized wrench. The Union Nut is shipped loose on sweat fitting connections. If chlorinated flux has been used, all parts are to be flushed thoroughly to avoid premature corrosion failure.

3. For installation of Hays PurePIC™ Pressure Independent Control Valve, please follow all the mounting and wiring diagram instructions below.

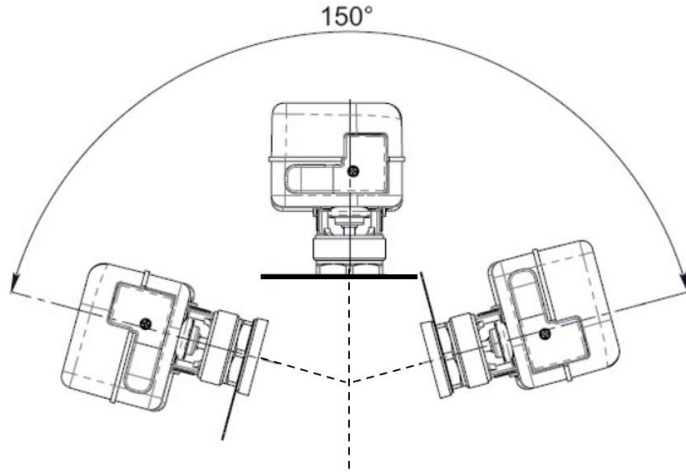

Figure1: Mounting instruction for PurePIC™ Pressure Independent Control Valve

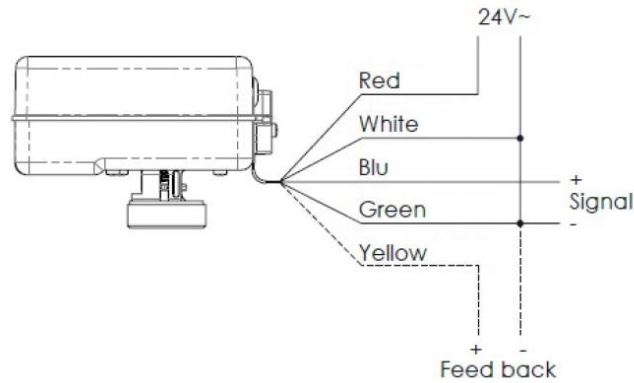

Figure2: Wiring diagram for PurePIC™ Pressure Independent Control Valve

MAINTENANCE

1. General maintenance is not required for PurePIC™ Pressure Independent Control Valve, however if the system experiences large amounts of pipe scale due to poor water conditions, as sometimes is found in older or retrofit systems, some may be required.
2. Provisions should be made to keep the system clean. Proper water treatment is also recommended.
3. When assembling the PurePIC™ Pressure Independent Control Valve to change the internal flow range cartridge set, always use new O-rings that will come along with the service kit order.
4. The actuator is equipped with a cable for electric connection and does not need maintenance.

LIMITED WARRANTY

See Hays Fluid Controls Current Terms & Conditions for warranty information.